

SDN™ Series Redundant Options

The SDN Series standard options allow for operation in a wide variety of applications. With the addition of an external redundancy module the SDN can also be used for true redundant operation including 2N and N+x configurations.

All SDN™ units include built in current sharing for parallel and redundant operation. All models ending in P also include a DC OK status relay contact. The external modules SDN2.5-20RED and SDN30/40RED increase the reliability by isolating the supplies and adding more signal options. Paralleling for increased power does not require the use of these modules.

Module Compatibility

Two separate modules are available to provide the maximum flexibility in size, cost and signaling capability. Refer to the chart below for information on which module can be used for each SDN power supply.

Power Rating – A simple yes or no indication that this module can or cannot handle the power rating of that power supply.

Input / Output Signals – Yes indicates that each power supply would have an independent relay contact to provide power supply status, and the DC bus output from the redundant module has it's own DC OK relay contact. Output only indicates that only the output of the redundant module would have a DC OK relay contact.



Features

- Smart power “DC OK Relay Contact”
- True Isolation
- High availability
- SDN features and quality

Applications

- Process Control
- Remote Location
- Critical production

Redundancy Module Compatibility Chart

Single Phase SDN™ Series		SDN2.5-24-100P*	SDN4-24-100LP*	SDN5-24-100P	SDN10-24-100P	SDN20-24-100P
SDN2.5-20RED	Power Rating	Yes	Yes	Yes	Yes	Yes
	Input / Output Signals	Yes	Yes	Yes	Yes	Yes
SDN30/40RED	Power Rating	Yes	Yes	Yes	Yes	Yes
	Input / Output Signals	Yes	Yes	Yes	Yes	Yes
Three Phase SDN™ Series		SDN5-24-480	SDN10-24-480	SDN20-24-480C	SDN30-24-480	SDN40-24-480
SDN2.5-20RED	Power Rating	Yes	Yes	Yes	No	No
	Input / Output Signals	Output Only	Output Only	Output Only	N/A	N/A
SDN30/40RED	Power Rating	Yes	Yes	Yes	Yes	Yes
	Input / Output Signals	Yes	Yes	Yes	Yes	Yes

* Paralleling will violate Class 2 current limits.

SDN™ Redundant Series Specifications for SDN2.5-20RED and SDN30/40RED

Catalog Number		
Description	SDN2.5-20RED	SDN30/40RED
Concept		
By means of a separate redundancy module, you can interconnect several identical SDN power supply units in a N+1 redundant mode. These external modules decouple the power supply outputs from each other so that, in case of failure, one power supply unit cannot overload the other units. The modules incorporate DC OK relay contacts.		
Electrical Characteristics		
Voltage		
-Nominal Value	24 VDC	
-Max. Rated	35 V	
Voltage Drop		
-Vin -> Vout	Typ. 0.6 V	
Current Handling Capacity		
-Maximum Nominal Value	20 A	40 A
Inverse Battery Protection	Yes	
Connection	Via captive screw terminals	
-Connector size range	Solid: 16-10 AWG (1.5 - 6 mm ²) Stranded: 16-12 AWG (1.5 - 4 mm ²)	Solid: 16-5 AWG (1.5 - 16 mm ²) Stranded: 16-8 AWG (1.5 - 10 mm ²)
Note: GND must be connected to module for voltage monitor to operate properly. See Connectors and Wiring diagrams.		
Relay Contacts		
DC Okay Contacts (qty) description	(1) V _{out} "OK" - N.O. & N.C. Contact	(1) V _{out} "OK" - N.O. Contact (2) V _{in} "OK" - N.O. Contact
-Voltage Set Point	> 18 VDC ±5%	
-Contact Rating	30 Vdc @ 2A / 250 V @ 2A	
DC OK LED	V _{out} "OK" Green LED	
-Voltage Set Point	> 18 VDC ±5%	
Dimensions		
(H x W x D) (in/mm)	4.88 in x 1.97in x 4.55 in (124 mm x 50 mm x 116 mm)	4.88 in x 2.56 in x 4.55 in (124 mm x 65 mm x 116 mm)
Free Space for Ventilation inches (mm)	Above/below: 0.39 in. (10 mm) recommended Left/Right: 0.39 in. (10 mm) recommended	
Weight (lbs/g)	1.38 lbs (625 g)	1.43 lb (646 g)
General		
Ambient Temperature	Storage: -25°C...+85°C Operation. -10°C...+60°C full power with operation to 70°C possible with a linear derating to half power from 60°C to 70°C (Convection cooling, no forced air required). Operation up to 50% load permissible with sideways or front side up mounting orientation. The relative humidity is < 90% RH, noncondensing; IEC 68-2-2, 68-2-3. For operation below -10°C, contact Technical Services.	

Wiring Diagram for SDN2.5-20RED

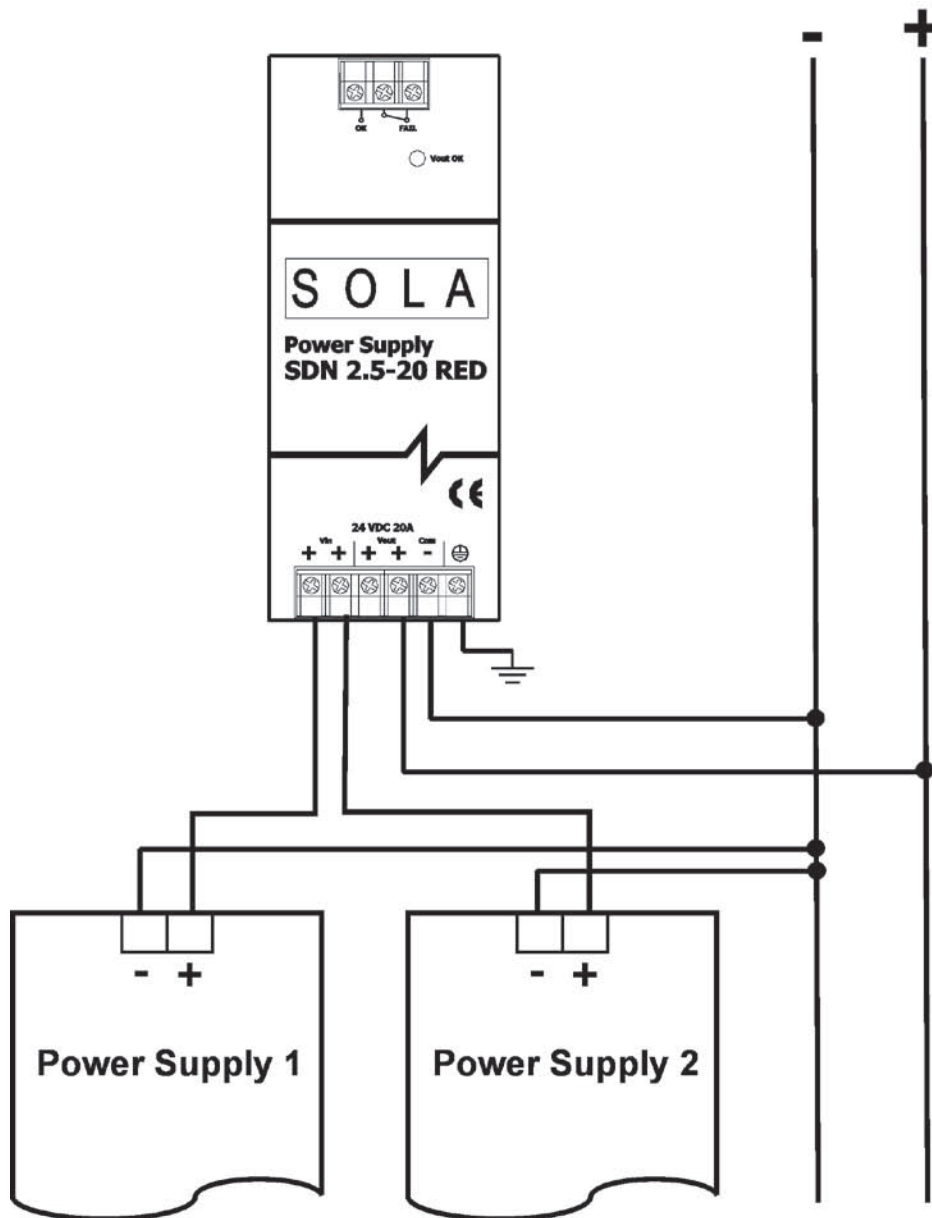
**Notes:**

1. The Common (marked "COM -") connection to the module is required for voltage monitoring (DC OK Contacts), and is not meant to be part of the current path from the power supply to the load.
2. Protective earth connection only provides protective ground to the metal case of the module. This connection is isolated from the positive and common connections

Wiring Diagram for SDN30/40RED

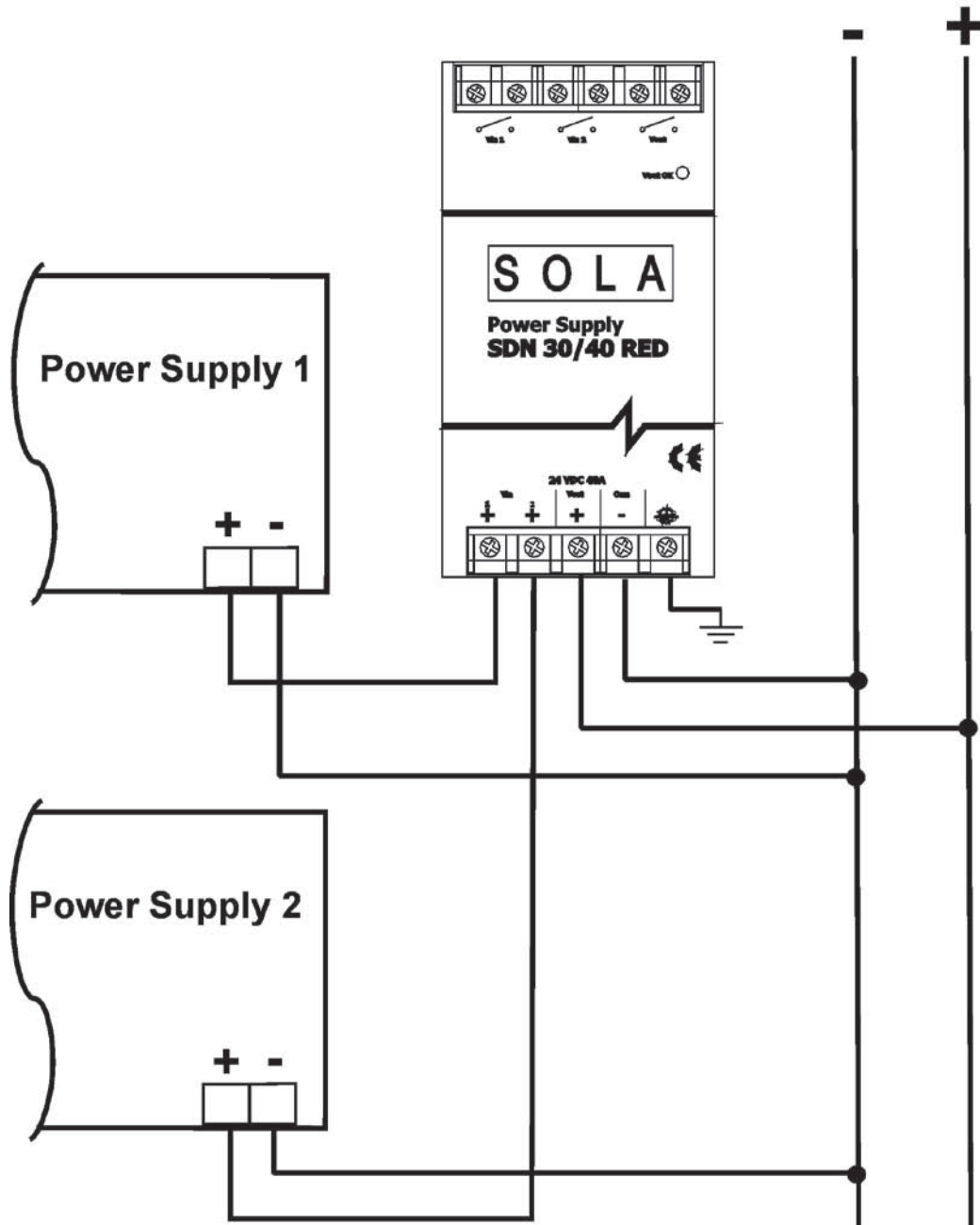

Notes:

1. The Common (marked "COM - ") connection to the module is required for voltage monitoring (DC OK Contacts), and is not meant to be part of the current path from the power supply to the load.
2. Protective earth connection only provides protective ground to the metal case of the module. This connection is isolated from the positive and common connections